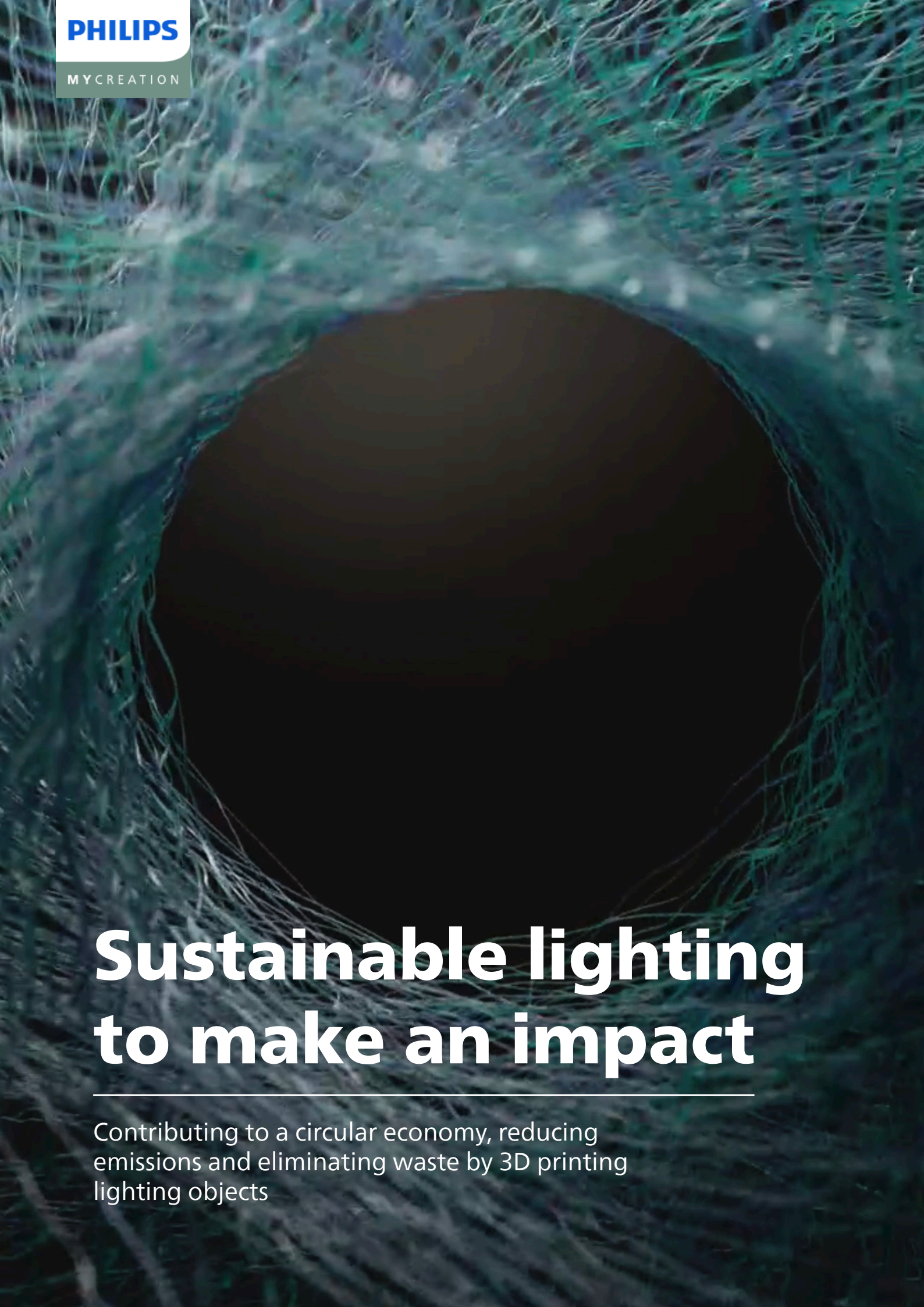

The Philips logo is displayed in white text on a blue rectangular background. Below it, the word 'MYCREATION' is written in white on a dark grey rectangular background.

PHILIPS

MYCREATION

The background of the entire page is a close-up photograph of a 3D printed object. The object is a circular ring with a complex, woven, or fibrous texture. It is illuminated from the side, creating a strong contrast between the bright, glowing edges and the dark, shadowed interior of the ring. The overall color palette is dominated by deep blues and greens, with some white highlights from the lighting.

# Sustainable lighting to make an impact

---

Contributing to a circular economy, reducing emissions and eliminating waste by 3D printing lighting objects

# index

03

## From waste to wonder

Sustainability as a matter of course

3D printed luminaires as part of a circular economy

10 Arguments for 3D printed luminaires

05

## A better solution: sustainable, circular bioeconomy

Revolutionary technology for a fundamental decision

Already working with 71.5% renewable granulate

Post-industrial recycling (PIR)

Post-consumer recycling (PCR)

08

## Less components for more flexibility

The freedom to design colors, shapes and textures

Enabling human and environmental health

09

## The assembly with disassembly in mind

Minimizing mechanical connections

10

## Heading towards the best recycling possible: 100%

Active involvement in international organizations

Pilot projects for a more complete recycling

11

## Lowering carbon emissions in materials and transport

12

## Committed to operating within the planet's limits

The only carbon-neutral lighting company

Beyond carbon neutrality: Signify's 2025 vision

Being a carbon neutral company

14

## Producing on demand Instead of on stock

From MTS to MT

15

## Each material is telling its own story

Once a deadly threat, now doing good: from fishing nets to print

07

## Luminaires

Polycarbonate: can protect cars but also the environment

16

## Better than recycling waste: not producing any

# From waste to wonder

---

Sustainability is by far one of the most important issues of our time. The fostering of long-term economic growth must not have a negative impact on other systems such as social or environmental. To achieve this goal, companies must address strategic and operational challenges. On the political-ecological side, it is the UN Paris Agreement that is forcing them to act. The message is clear: Future economic success must go hand in hand with sustainable thinking and action.

## Sustainability as a matter of course

---

To remain competitive, successful and a leader, we at Signify are consistently working on the holistic transformation to a sustainable company. In addition to our operational commitments such as being carbon neutral in our operations and using 100% renewable electricity, we place great emphasis on the sustainability of our products – a matter of course for a leading global manufacturer of consumer goods.

Since the earth is known to have limited resources we are obliged to work on transformation of material flows: from linear into circular, from finite into renewable, from virgin into recycled and bio-circular. In a circular economy, material consumption should be a circular process where renewable resources and waste streams are reduced, reused, repaired, refurbished and recycled.

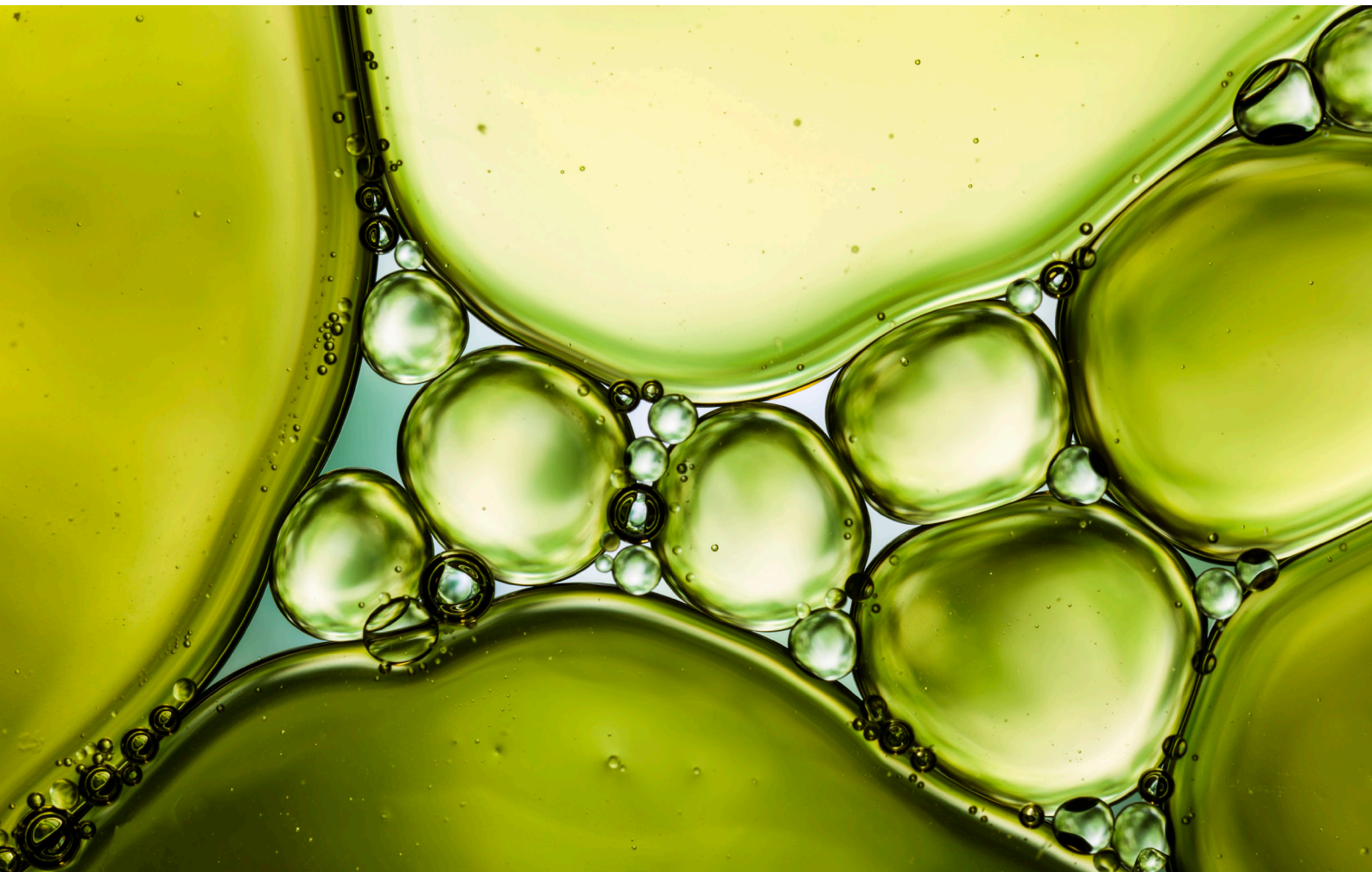

## 3D printed luminaires as part of a circular economy

---

3D printing is a highly flexible, more sustainable form of manufacturing, in which luminaires can be made with raw material that has already recycled, tailored to the customer's exact needs and recycled at the end of their life. In Signify's 3D printed luminaires, nearly every component may be reused or recycled – thanks to a consistent disassembly concept –, supporting the concept of a circular economy. They are printed only on demand, which enables a significant reduction in inventory – another important factor in terms of overall sustainability, just like the best possible avoidance of waste in production.

## 10 arguments for 3D printed luminaires

---

- 1 On target to reach at least 55% recycled or bio-circular plastics used for production of printed parts
- 2 Up to 40% fewer components
- 3 Easy to disassemble
- 4 100% recyclable materials (only in Europe)
- 5 Up to 76% less carbon emissions in material sourcing and manufacturing
- 6 Up to 28% less carbon emissions in transport
- 7 Carbon neutral production
- 8 Print on demand: no stock of unsold products
- 9 Using waste to create products
- 10 Working towards zero waste production

# A better solution: sustainable, circular bioeconomy

---

**An elementary component of ecological sustainability strategies is to move away from the use of virgin materials for the production of goods. Using fewer fossil resources – and more recycled and bio-circular sources instead – is an important step toward stopping global warming and preserving the earth’s foundations of life. In particular, the consumption and processing of petroleum over the last 150 years have affected the climate in a highly damaging way. It has long been proven that a fundamental change urgently needs to happen.**

## Revolutionary technology for a fundamental decision

---

Part of this change is behavioral, but an equally important part is technology. One of the technologies contributing to the urgently needed change is 3D printing. Today, it is even possible to build houses with appropriately sized 3D printers. The revolutionary concept and the rapidly developing technology of the last years represent a turning point in production contexts. The various reasons for the superiority of the 3D printing concept are given below. Before that, one decision is at the heart of sustainability thinking: moving away from virgin raw materials as feedstock.

The solution to this fundamental issue sounds simpler than it is in industrial reality: the transition to the exclusive use of mass balanced bio-circular, post-industrial recycled and post-consumer recycled material. The combination of these three sources will be required to meet the demand for sustainable raw materials. For its 3D-printed luminaires, Signify no longer uses virgin materials for the 3D printed parts, but works with all three eco-friendly materials mentioned above.

## Already working with 71.5% Renewable granulate

---

Bio-circular mass balanced raw materials are materials from ISCC PLUS (International Sustainability and Carbon Certification) certified waste streams and residues. These can be tall oil from the wood processing industry or used cooking oil. The bio-circular granulate used as raw material for Signify's 3D-printed luminaires is ISCC PLUS certified and 71.5% renewable. Based on the colors and additives used in production alone, the officially mass-balanced rate will be "at least 55%".

### **GOOD TO KNOW: ISCC PLUS**

ISCC PLUS is a globally applicable sustainability certification system for fully traceable and deforestation-free supply chains.



## Post-Industrial Recycling (PIR)

---

Post-industrial recycling refers to waste that comes from the manufacturing process that led to the creation of the starting material. An example of this is the production of polycarbonate (PC) building materials, as for example the sheets for car ports, swimming pools or illuminated advertising. As of June

2022, Signify has implemented PIR raw materials from the carport industry for three product series. Again, based on colors and additives used in production, the publicly stated rate for printed parts is “at least 65% recycled”, while the actual recycled content of post-industrial recycled granulate is 80%.

## Post-Consumer Recycling (PCR)

---

Post-consumer recycled material refers to the recycling of used goods. Standard PCR content includes packaging material, plastic bottles, or aluminum cans. Signify made a limited-edition table light of which the lampshade is made with 70% post-consumer recycled compact discs. For a pendant light, another limited edition, the lampshade is printed with 100% post-consumer recycled fishing nets. The fishing nets and also the shades consist of nylon material.



# Less components for more flexibility

Apart from the issue of source material, 3D printing manufacturing offers several advantages. One of these is the integration of multiple functions into a single component, e.g. the integration of the strain relief into the housing of a luminaire. In this way, two screws and a plastic part are typically removed from the assembly. As an important side effect, this allows for easy and quick disassembly, as the strain relief does not need to be separated into one or more waste streams. Finally, one assembly step is taken out of the production process, which increases its efficiency. Where conventional production technology required two parts and a corresponding connection, a single part is now sufficient.

## The freedom to design Colors, Shapes and Textures

The next advantage of 3D printing technology is its flexibility and design freedom, as it allows for an almost unlimited number of different component shapes – an impossibility with traditional production methods such as injection moulding, which is always restricted by the mould release. With 3D printing there is no such limitation. Therefore, Signify products can have any design you want.



Traditional metal luminaire



Signify 3D printed luminaire

disassembly:	8.5 minutes	3 minutes
components:	32	18
colour paints:	2	0
screws and washers:	14	6 screws, 0 washers
material groups for recycling:	9	5 pure material groups

## Enabling human and environmental health

In the U.S., Signify has received the Declare certification for two product lines: Signify Lightolier BA Series and Cooper 200 Lighting Series. Declare is a label to highlight healthy building products, awarded with the aim of enabling the

creation of buildings that support human and environmental health. It is issued by the International Living Future Institute, a non-governmental organization committed to catalyzing a global transformation toward true sustainability.



# The assembly with disassembly in mind

---

When the life of a luminaire comes to an end and it is time to recycle it, it is important that disassembly is as simple as possible. A 3D printed luminaire consists not only of printed materials, but also of non-printable components such as LEDs, drivers (which in turn

consist of electronic components) and metals (such as heat sinks and screws). In End-of-Life recycling, the various components need to be disassembled and sent to separate waste streams, where they can be appropriately recycled.

---

Another contribution to easy disassembly is the minimization of mechanical connections by glue or screws – by replacing them with click components. Design guidelines limit the use of glue, the number of screws and the number of fixed “one time” click connections. To effectively support End-of-Life recycling, each product is provided with disassembly instructions. This enables the recycler to easily separate the different parts and transfer them to the correct waste streams.

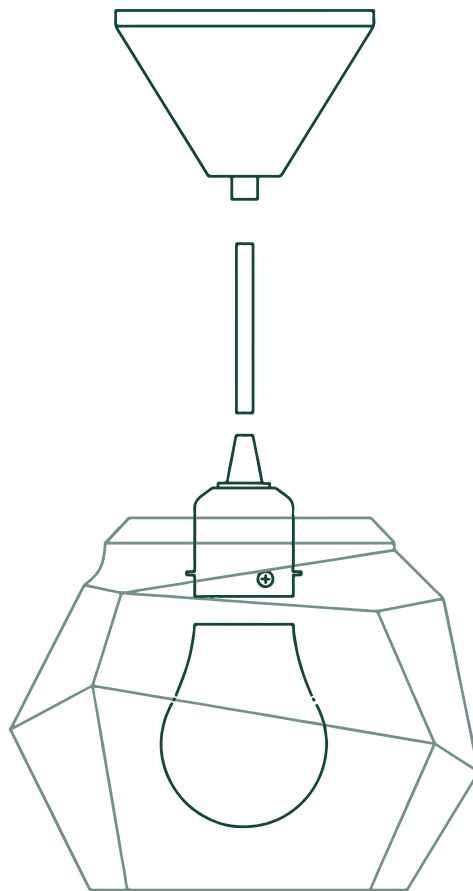

# Heading towards the best recycling possible: 100%

---

The collection and recycling of End-of-Life electrical equipment is mandatory in EU Member States due to the EU WEEE (Waste of Electrical and Electronic Equipment) Directive: “This Directive lays down measures to protect the environment and human health by preventing or reducing the adverse impacts of the generation and management of waste from electrical and electronic equipment and by reducing overall impacts of resource use and improving the efficiency of such use (...), thereby contributing to sustainable development.”

## Active involvement in international organizations

---

Accordingly, all lighting products, lamps and luminaires, must be collected and recycled at the end of their life. To finance this, the sales price for each new product sold includes a national fee. Each EU Member State has its own WEEE based regulations and is organizing collection

and recycling on national level via the national CRSO (Collection and Recycling Service Organization). Signify is actively involved in many countries and has a seat on the board of several lamps and lighting CRSOs.

## Pilot projects for a more complete recycling

---

Components such as glass and metals can be recycled very well, and the recycling rate is already quite high. With plastics, things are a bit more complex. There are many types of plastics, all with different properties, such as melting temperature. It is difficult to separate the different types of plastic when they are

mixed. Polycarbonate is a high-quality plastic that can be recycled when kept separate. Therefore, Signify has organized dedicated pilots in the U.S. and EU to prove that luminaires, including PC, can be recycled at the end of their life cycle.



# Lowering carbon emissions in materials and transport

---

**Research shows that better air quality by reducing emissions from fossil fuel combustion and other sources to slow climate change would improve human health and prevent economic losses. In a 2020 study, Philips Innovation Services, Environment & Safety compared the Life Cycle Assessment of a traditionally manufactured downlight with a die cast aluminum housing with a 3D printed downlight, both delivering the same amount of light.**

The following points were considered in the study:

- all components (excluding packaging)
- type of components
- material of components
- weight of components
- manufacturing method of components
- component supplier location
- mode of transport

The impressive result of the study showed significant savings of up to 76% in material supply and manufacturing and up to 28% in transportation.

Eliminating die casting for housings is critical to reducing carbon emissions because a lot of heat is required to create the metal housings. The avoidance of metal housings also helps to decrease emissions for transport by reducing the luminaire's weight by more than 20% – a critical factor when transporting products.



# Committed to operating within the planet's limits

---

**“We are very proud to be carbon neutral already in 2020, ahead of our target (...) It is a truly significant achievement for us and we call on many others to join us in pushing for carbon neutral operations.”**

**Signify's Head of Sustainability, Environment, Health & Safety**

## The only carbon-neutral lighting company

---

With climate change and increasing amounts of waste threatening our planet and its inhabitants, we at Signify have put sustainability goals at the center of everything we do. To achieve these goals, we have developed a strategy called “Brighter Lives, Better World” – and are

already in the second phase, having met all our initial goals ahead of schedule. For example, by 2020 we were already the only lighting company to operate on a completely climate-neutral basis including the use of 100% renewable electricity.

## Beyond carbon neutrality: Signify's 2025 vision

---

Encouraged by the early achievement of all targets, the company's sustainability goals for the years from 2020 to 2025 were formulated even more ambitiously:

- Double the pace of the Paris Agreement
- Double circular revenues to 32%
- Double our revenues for brighter lives which benefit society to 32%
- Double our percentage of women in leadership to 34%
- Increase climate action revenues to 72%
- Zero waste to landfill for all manufacturing sites
- Supplier sustainability performance of 95%

## Being a carbon neutral company

---

On the way to becoming climate neutral, a wide variety of projects have been successfully launched in all areas of the company.

Industrial Operations	Non-Industrial Operations	Logistics	Business Travel
<ul style="list-style-type: none"><li>Energy efficiency projects</li><li>Energy savings walkthroughs</li><li>Reduction of energy consumption in energy intensive operations</li><li>Reduction of critical substances use</li></ul>	<ul style="list-style-type: none"><li>Flex-working across the organization</li><li>Intelligent systems regulating lighting and heating</li><li>Efficient use of spaces</li></ul>	<ul style="list-style-type: none"><li>Continuous check of supply chain</li><li>Reduction of logistical operations</li><li>Use of environmentally friendly carriers</li><li>Transparency on the environmental impact of our ocean transportation</li></ul>	<ul style="list-style-type: none"><li>Reduction targets for each business department</li><li>Efficient models enabling remote work and eliminating the need for travel</li></ul>

# Producing on demand instead of on stock

---

Environmental aspects play an important role in reducing global warming – lowering CO2 emission rates is one of the goals in designing a sustainable supply chain. A big step toward supply chain sustainability is the minimization of inventory, as warehousing has the potential for product waste and harmful greenhouse gas emissions. Since 3D printed luminaires are produced only on demand, there is no need to stock finished goods.

## From MTS to MT

---

Make-to-stock (MTS) is a manufacturing method based on forecasted product demand. Once manufactured, products are kept in stock until they are sold. The alternative is called Make-to-order (MTO) and starts production only after receipt of a confirmed customer order. This allows

consumers to purchase products that are customized to their specifications. No inventory of finished goods is required, as only non 3D printed parts such as drivers or LEDs need to be stored – being able to use them for different products.

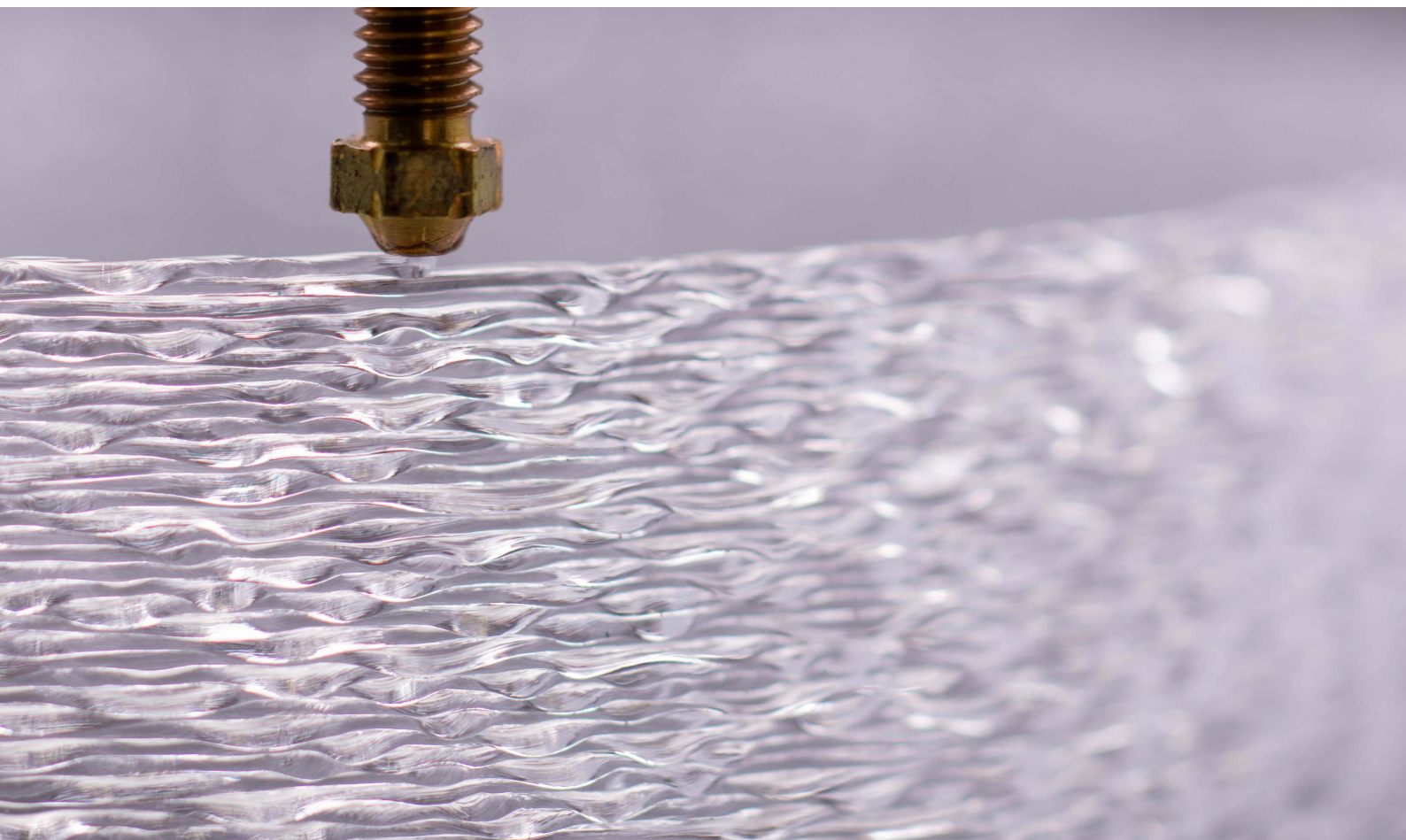

# Each material is telling its own story

---

## Once a deadly threat, now doing good: from fishing nets to print luminaires

---

On our mission to produce lighting as sustainably as possible, we have decided to adopt plastic recycling processes and use post-consumer recycled materials. One of our partners Fishy Filaments produces a high-quality granulate, the base material for 3D printer filament. Made from 100% recycled marine nylon, no pigments or other modifiers are added. Instead, Fishy Filaments works with the nets they receive, sorting them by color and wear. While also supporting fishing communities by taking End-of-Life fishing gear, it is the environmental impact that has the greatest impact in a sustainability assessment.

The Philips MyCreation Coastal Breeze shades are made from a specially made 100% recycled blend and were awarded the Gold Award by the Industrial Design Society of America at their 2022 IDEA awards.

Up to 46% of ocean plastic consists of fishing nets – often thrown into the sea, they endanger the lives of marine animals. Converting this waste into 3D filaments actually saves those lives: One luminaire contains 4.5 meters of fishing nets, so each Coastal Breeze luminaire saves four sea creatures.

## Polycarbonate: can protect cars but also the environment

---

Another raw material used as an alternative to virgin raw materials is post-industrial waste. In this case, the 3D printer filament is made from recycled plastics produced during the manufacture of polycarbonate sheets for carports, advertising signs or swimming pool covers. The waste material is sent to a grinding company that specializes in grinding transparent PC.



# Better than recycling waste: not producing any

---

There is only one thing better than recycling waste: producing no waste at all. That is why we are actively investing in our “Towards Zero Production Waste” program. We are working to improve yields at all our production sites. In filament production, there are some rejects that we chop and use to make new filament. In the production of printed parts, there can be some misprints and leftovers. These misprints and leftovers are granulated and sent back to filament production to make new filament. In this way, we reuse our own production waste.







**Let us assist you in achieving  
your sustainable goals**

[pro.mycreation.lighting.philips.com](https://pro.mycreation.lighting.philips.com)

